

JVC

SERVICE MANUAL

CD PORTABLE SYSTEM

RD-T7GN RD-T5BU

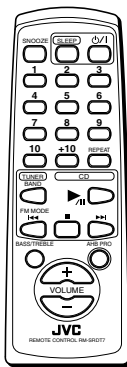

[RD-T7GN Only]

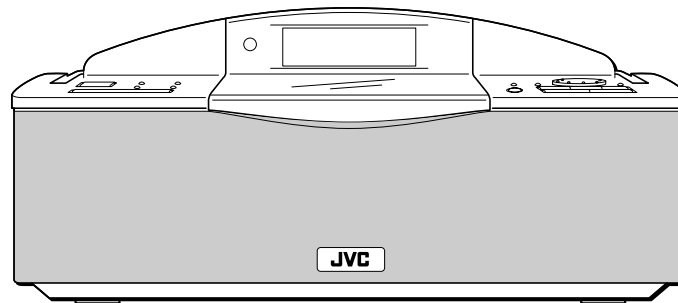

COMPACT
disc
DIGITAL AUDIO

Area Suffix

J ----- U.S.A.
C ----- Canada

Comparison table

Item	RD-T5BU	RD-T7GN
AHB	Not used	Used
Back light (LCD)	Not used	Used
Remote control	Not used	Used

Contents

Safety precautions	1-2	Flow of functional operation until TOC read ----	1-15
Preventing static electricity	1-3	Maintenance of laser pickup	1-16
Important for laser products	1-4	Replacement of laser pickup	1-16
Importance administering point on the safety ----	1-5	Description of major ICs	1-17
Disassembly method	1-6	Wiring connection	1-25
Adjustment method	1-13		

Safety Precautions

1. This design of this product contains special hardware and many circuits and components specially for safety purposes. For continued protection, no changes should be made to the original design unless authorized in writing by the manufacturer. Replacement parts must be identical to those used in the original circuits. Services should be performed by qualified personnel only.
2. Alterations of the design or circuitry of the product should not be made. Any design alterations of the product should not be made. Any design alterations or additions will void the manufacturer's warranty and will further relieve the manufacture of responsibility for personal injury or property damage resulting therefrom.
3. Many electrical and mechanical parts in the products have special safety-related characteristics. These characteristics are often not evident from visual inspection nor can the protection afforded by them necessarily be obtained by using replacement components rated for higher voltage, wattage, etc. Replacement parts which have these special safety characteristics are identified in the Parts List of Service Manual. Electrical components having such features are identified by shading on the schematics and by (\triangle) on the Parts List in the Service Manual. The use of a substitute replacement which does not have the same safety characteristics as the recommended replacement parts shown in the Parts List of Service Manual may create shock, fire, or other hazards.
4. The leads in the products are routed and dressed with ties, clamps, tubings, barriers and the like to be separated from live parts, high temperature parts, moving parts and/or sharp edges for the prevention of electric shock and fire hazard. When service is required, the original lead routing and dress should be observed, and it should be confirmed that they have been returned to normal, after re-assembling.
5. Leakage current check (Electrical shock hazard testing)

After re-assembling the product, always perform an isolation check on the exposed metal parts of the product (antenna terminals, knobs, metal cabinet, screw heads, headphone jack, control shafts, etc.) to be sure the product is safe to operate without danger of electrical shock.

Do not use a line isolation transformer during this check.

 - Plug the AC line cord directly into the AC outlet. Using a "Leakage Current Tester", measure the leakage current from each exposed metal parts of the cabinet, particularly any exposed metal part having a return path to the chassis, to a known good earth ground. Any leakage current must not exceed 0.5mA AC (r.m.s.).
 - Alternate check method

Plug the AC line cord directly into the AC outlet. Use an AC voltmeter having, 1,000 ohms per volt or more sensitivity in the following manner. Connect a 1,500 Ω 10W resistor paralleled by a 0.15 μ F AC-type capacitor between an exposed metal part and a known good earth ground. Measure the AC voltage across the resistor with the AC voltmeter.

Move the resistor connection to each exposed metal part, particularly any exposed metal part having a return path to the chassis, and measure the AC voltage across the resistor. Now, reverse the plug in the AC outlet and repeat each measurement. Voltage measured any must not exceed 0.75 V AC (r.m.s.). This corresponds to 0.5 mA AC (r.m.s.).

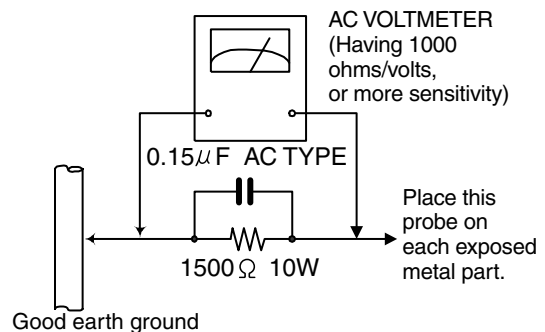

Warning

1. This equipment has been designed and manufactured to meet international safety standards.
2. It is the legal responsibility of the repairer to ensure that these safety standards are maintained.
3. Repairs must be made in accordance with the relevant safety standards.
4. It is essential that safety critical components are replaced by approved parts.
5. If mains voltage selector is provided, check setting for local voltage.

CAUTION

Burrs formed during molding may be left over on some parts of the chassis. Therefore, pay attention to such burrs in the case of preforming repair of this system.

In regard with component parts appearing on the silk-screen printed side (parts side) of the PWB diagrams, the parts that are printed over with black such as the resistor (■), diode (▣) and ICP (●) or identified by the " \triangle " mark nearby are critical for safety.

When replacing them, be sure to use the parts of the same type and rating as specified by the manufacturer. (Except the J and C version)

Preventing static electricity

1. Grounding to prevent damage by static electricity

Electrostatic discharge (ESD), which occurs when static electricity stored in the body, fabric, etc. is discharged, can destroy the laser diode in the traverse unit (optical pickup). Take care to prevent this when performing repairs.

2. About the earth processing for the destruction prevention by static electricity

Static electricity in the work area can destroy the optical pickup (laser diode) in devices such as CD players. Be careful to use proper grounding in the area where repairs are being performed.

2-1 Ground the workbench

Ground the workbench by laying conductive material (such as a conductive sheet) or an iron plate over it before placing the traverse unit (optical pickup) on it.

2-2 Ground yourself

Use an anti-static wrist strap to release any static electricity built up in your body.

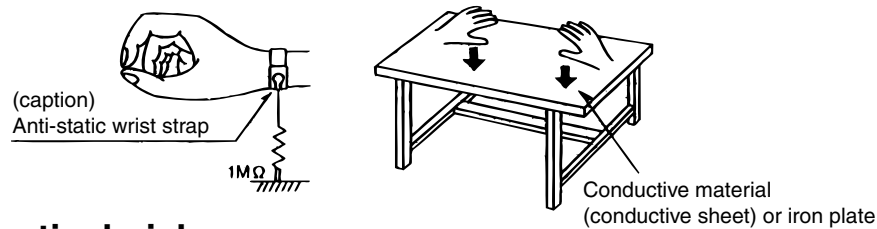

3. Handling the optical pickup

1. In order to maintain quality during transport and before installation, both sides of the laser diode on the replacement optical pickup are shorted. After replacement, return the shorted parts to their original condition. (Refer to the text.)
2. Do not use a tester to check the condition of the laser diode in the optical pickup. The tester's internal power source can easily destroy the laser diode.

4. Handling the traverse unit (optical pickup)

1. Do not subject the traverse unit (optical pickup) to strong shocks, as it is a sensitive, complex unit.
2. Remove solder of the land on the flexible cable after replacing the optical pickup. For specific details, refer to the replacement procedure in the text. Remove the anti-static pin when replacing the traverse unit. Be careful not to take too long a time when attaching it to the connector.
3. Handle the flexible cable carefully as it may break when subjected to strong force.
4. It is not possible to adjust the semi-fixed resistor that adjusts the laser power. Do not turn it

Attention when traverse unit is decomposed

***Please refer to "Disassembly method" in the text for pick-up and how to detach the substrate.**

1. Short the land before the card wire is removed from connector on the Main board as shown in Figure.
(When the wire is removed without putting up solder, the CD pick-up assembly might destroy.)
2. Please remove solder after connecting the card wire with when you install picking up in the substrate.

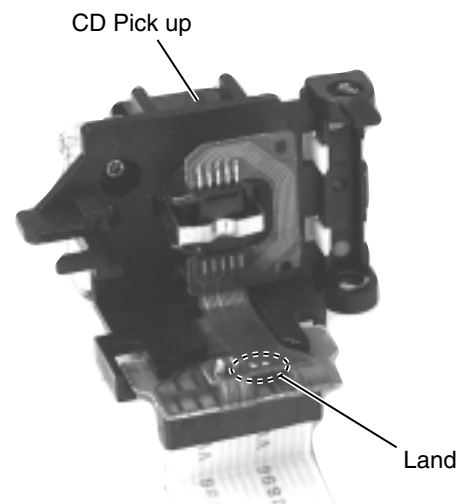

Important for laser products

1. CLASS 1 LASER PRODUCT

2. DANGER : Invisible laser radiation when open and interlock failed or defeated. Avoid direct exposure to beam.

3. CAUTION : There are no serviceable parts inside the Laser Unit. Do not disassemble the Laser Unit. Replace the complete Laser Unit if it malfunctions.

4. CAUTION : The compact disc player uses invisible laserradiation and is equipped with safety switches which prevent emission of radiation when the drawer is open and the safety interlocks have failed or are defeated. It is dangerous to defeat the safety switches.

5. CAUTION : If safety switches malfunction, the laser is able to function.

6. CAUTION : Use of controls, adjustments or performance of procedures other than those specified herein may result in hazardous radiation exposure.



CAUTION Please use enough caution not to see the beam directly or touch it in case of an adjustment or operation check.

VARNING : Osynlig laserstrålning är denna del är öppnad och spårren är urkopplad. Betrakta ej strålen.

VARO : Avattaessa ja suojalukitus ohitettaessa olet alltiina näkymättömälle lasersäteilylle. Älä katso säteeseen.

ADVARSEL : Usynlig laserstrålning ved åbning , når sikkerhedsafbrydere er ude af funktion. Undgå udsættelse for stråling.

ADVARSEL : Usynlig laserstrålning ved åbning, når sikkerhedsbryteren er avslott. unngå utsettelse for stråling.

REPRODUCTION AND POSITION OF LABELS

WARNING LABEL

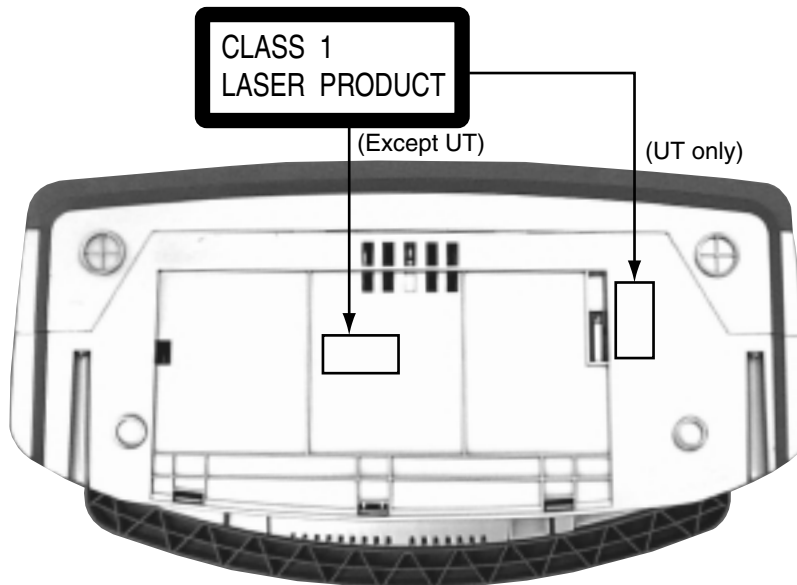

Importance administering point on the safety

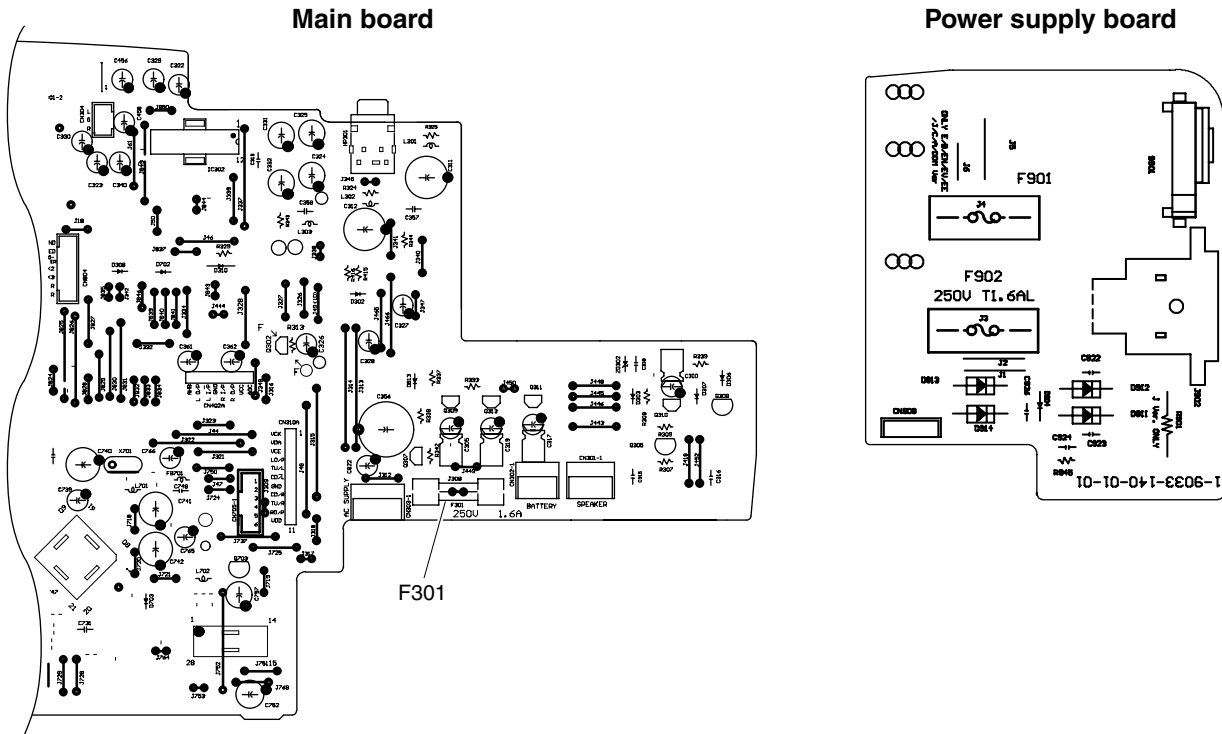

For USA and Canada / pour États - Unis d'Amérique et Canada

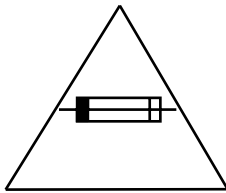

Caution: For continued protection against risk of fire, replace only with same type 1.6A/250V for F301 and F902. This symbol specifies type of fast operating fuse.

Précaution: Pour éviter risques de feux, remplacez le fusible de sûreté de F301 et F902 comme le même type que 1.6A/250V.

Ce sont des fusibles sûretés qui fonctionnent rapide.

Disassembly method

<Main body section>

■ Removing the front cabinet assembly and rear cabinet assembly (See Fig.1 to 4)

1. Remove the two screws "A" and two screws "B" retaining the front cabinet and rear cabinet assemblies from the rear of the body.
2. Remove the battery door from the rear of the body, then remove the screw "C" retaining the front cabinet and rear cabinet assemblies.
3. Remove the two screws "D" retaining the CD door lens from the top of the body with a hexagonal wrench.

[Caution] · If the CD door cannot be opened, the screws "E" which are to be removed in step 4 will not be removable. In this case, it is necessary to remove the CD door lens.

- Removing the CD door lens also removes the LCD lens together with it. Be sure to attach the LCD lens when attaching the CD door lens later.

4. Remove the two screws "E" retaining the front cabinet assembly from the top of the body.
5. Disconnect the wire from the connector CN301-1 on the main board assembly, then remove the front cabinet assembly from the rear cabinet assembly.

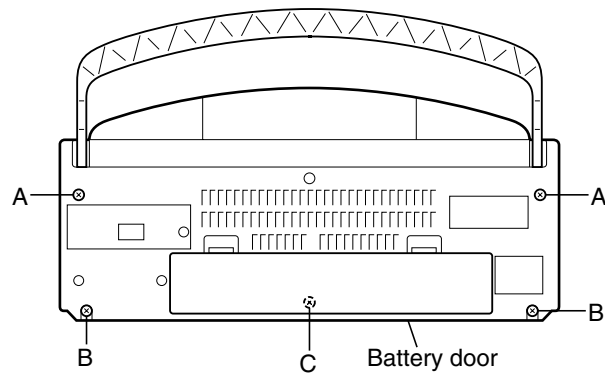

Fig.1

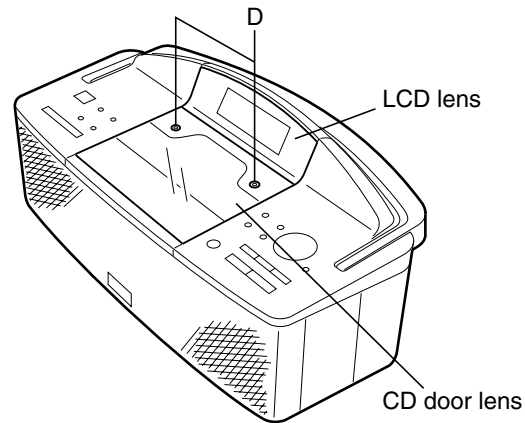

Fig.2

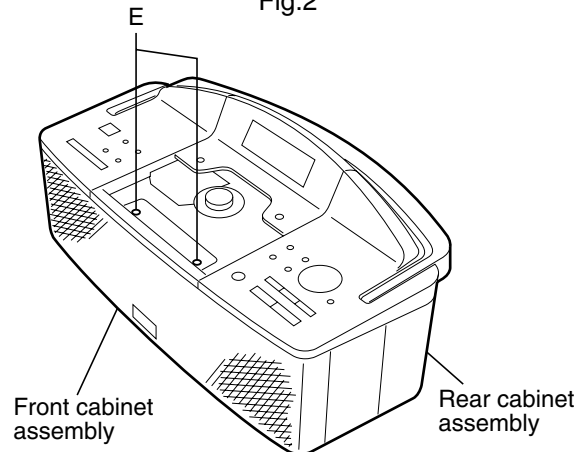

Fig.3

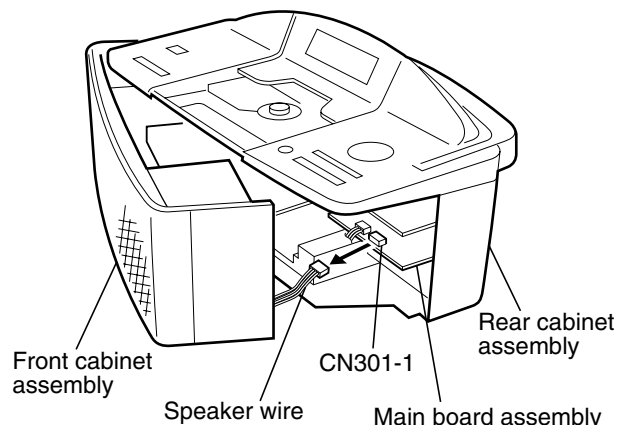

Fig.4

<Front cabinet section>

- Prior to performing the following procedures, remove the front cabinet assembly from the rear cabinet assembly.

■ Remove the right and left speaker assemblies (See Fig.5 and 6)

1. Remove the six screws "F" retaining the speaker grille from the inside of the front cabinet assembly.
2. Remove the clamp fixing the speaker wires.

[Note] When installing the speaker assemblies, pass each speaker wire through the notch " a " or " a' " at the bottom of the front cabinet before clamping the wire.

3. Remove the eight screws "G" retaining the right and left speaker assemblies from the outside of the front cabinet assembly.

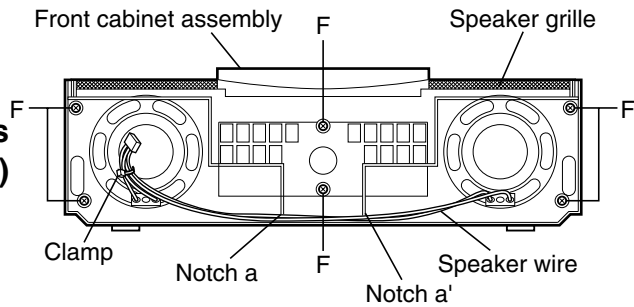

Fig.5

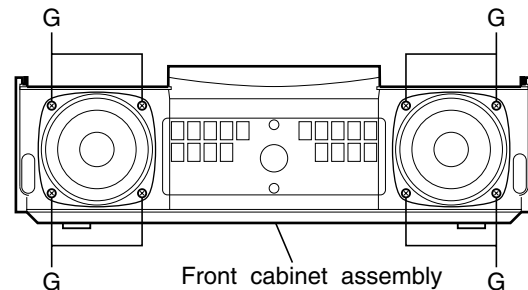

Fig.6

<Rear cabinet section>

- Prior to performing the following procedures, remove the front cabinet assembly from the rear cabinet assembly.

■ Removing the top cabinet assembly (See Fig.7 to 9)

1. Remove the screw "H" retaining the top cabinet assembly from the rear of the rear cabinet assembly.
2. Disconnect the wires from the connectors CN302-1 and CN303-1 on the main board assembly at the front of the rear cabinet assembly.
3. Remove the screw "I" clamping the FM antenna wire.
4. Pull the top cabinet assembly slightly towards front and separate it from the rear cabinet assembly, then remove the antenna wire from the post pin on the main board assembly and remove the top cabinet assembly.

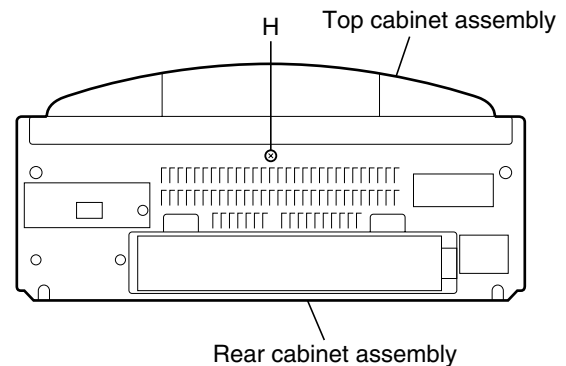

Fig.7

[Caution] When installing the top cabinet assembly, be sure to connect the FM antenna wire.

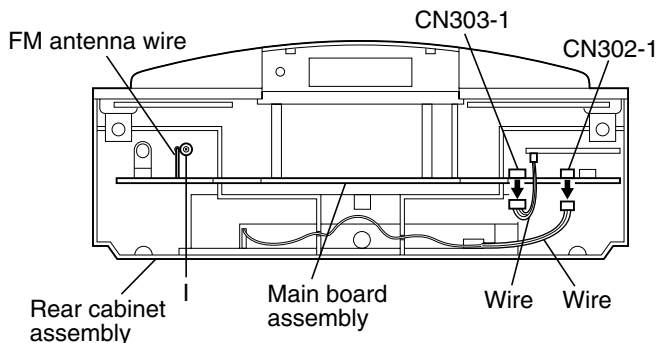

Fig.8

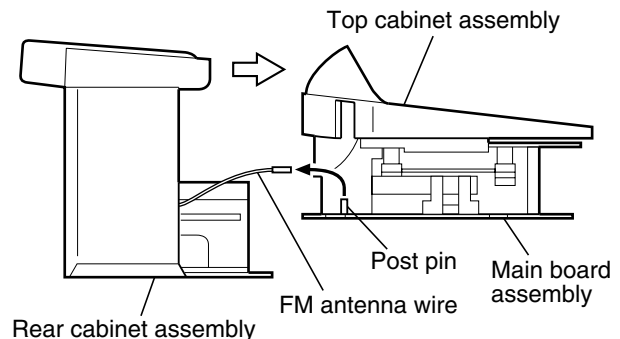

Fig.9

■ Removing the power supply board assembly and transformer assembly (See Fig.10)

- Prior to performing the following procedures, remove the top cabinet assembly from the rear cabinet assembly.
1. Remove the two screws "J" retaining the power supply board assembly.
 2. Remove the two screws "K" retaining the transformer assembly.
 3. Pull out the power board assembly from notches " b " and " b' " and remove it together with the transformer assembly.

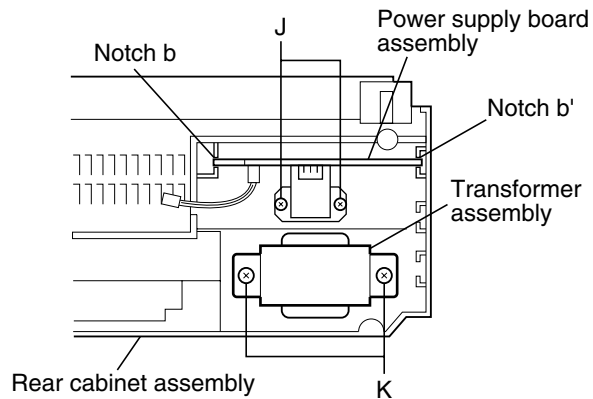

Fig.10

■ Removing the battery board assembly (See Fig.11 and 12)

1. Disconnect the wire from the connector CN302-1 on the main board assembly.
2. Remove the solder " c " fixing the wire.
3. Lift the claw " e " on the bottom of the rear cabinet assembly slightly and remove the battery board assembly by pulling it in the direction of the arrow.

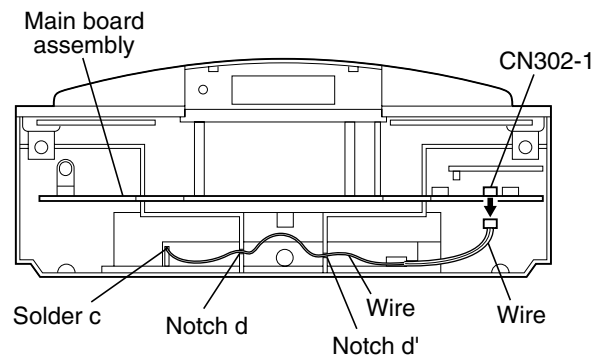

Fig.11

[Note] When installing the battery board assembly, pass the wires through the notches " d " and " d' " at the bottom of the rear cabinet.

■ Removing the handle (See Fig.13)

- Prior to performing the following procedures, remove the top cabinet assembly from the rear cabinet assembly.
1. Open hooks " f " and " f' " on the left and right sides of the rear cabinet assembly and remove the handle by pulling it toward the rear.

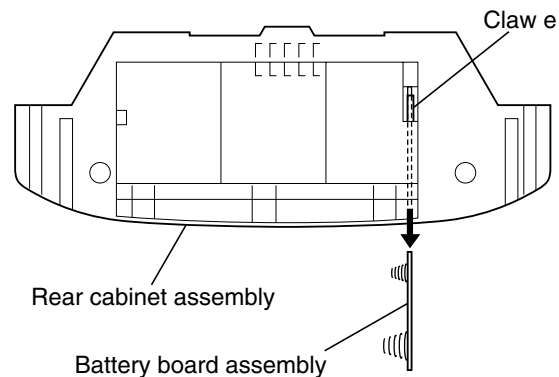

Fig.12

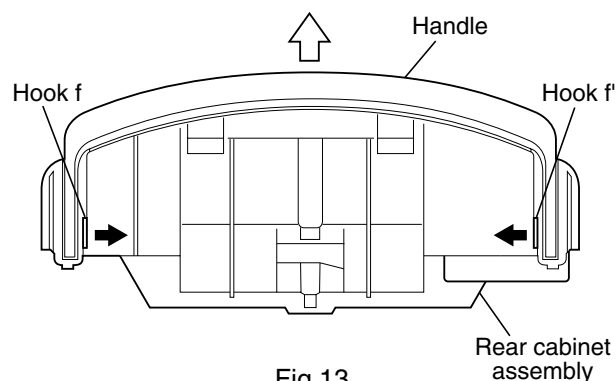

Fig.13

<Top cabinet section>

[Caution] When removing the board assembly, be careful not to scratch or damage the top cabinet or the CD door.

■ Removing the main board assembly (See Fig.14 to 16)

1. Remove the three screws "L" retaining the main board assembly.
2. Disconnect the wire and card wires from the connectors CN708-1, CN801-2 and CN802-2 on the main board assembly.
3. Disconnect the wire from the connector CN804-1 on the key 2 board assembly.
4. Disconnect the wire from the connector P011 on the CD mechanism board assembly.
5. Lift the main board assembly slightly in the direction of the arrow and apply solder to short round section "g" on the CD pickup unit.

[Caution] Be sure to apply solder in order to short round section "g" on the CD pickup unit before removing the wire from the CD pickup unit (see Fig. 16).
If the card wire is removed without applying this solder, the CD pickup may be damaged.

6. After soldering, disconnect the card wire from the connector CN701 on the main board assembly.

[Caution] After re-connecting the card wire, be sure to remove the solder from short round.

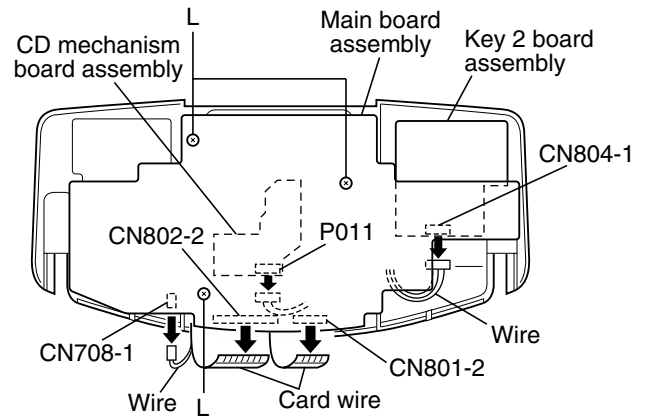

Fig.14

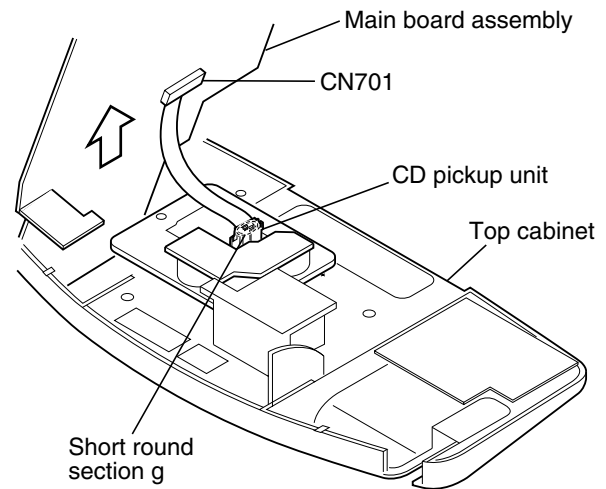

Fig.15

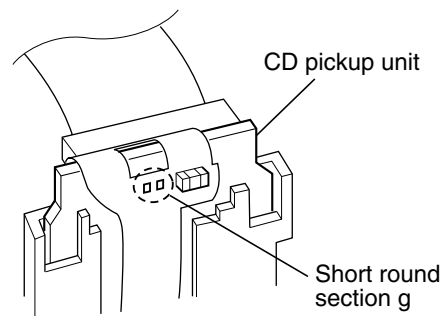

Fig.16

■ Removing the key 1 board assembly (See Fig.17)

1. Remove the four screws "M" retaining the key 1 board assembly from the back side of the top cabinet assembly.

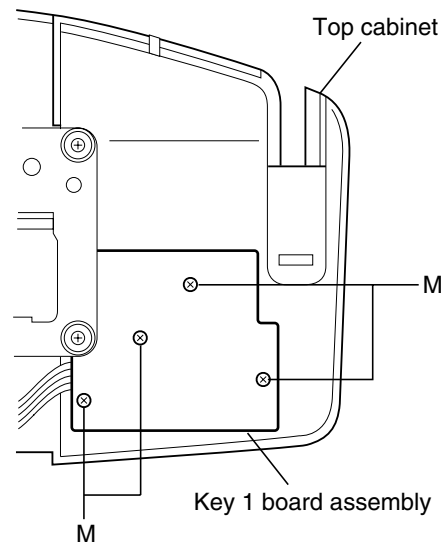

Fig.17

■ Removing the key 2 board assembly and jog board assembly (See Fig.18 and 19)

1. Insert a thin tool such as the tip of a thin screwdriver into the hole "h" at the back of the top cabinet assembly and push out the jog knob toward the front of the top cabinet assembly.
2. Remove the nut "N" and washer retaining the shaft at the top of the top cabinet assembly.
3. Remove the five screws "O" retaining the key 2 board assembly from the back side of the top cabinet assembly.
4. Take out the key 2 board assembly and the jog board assembly together.

[Note] Operation knobs are present below the key 2 board assembly. Be sure to install these in their correct orientations when installing the key 2 board assembly (see Fig. 20).

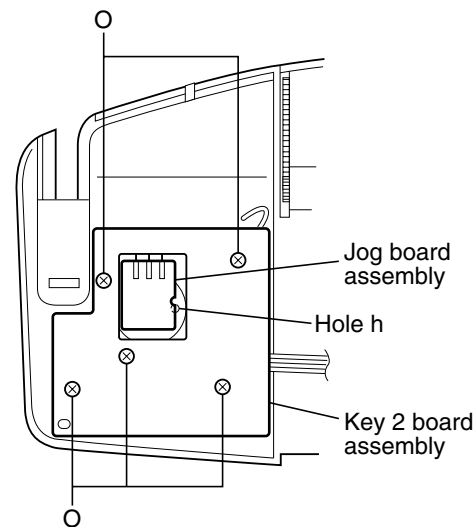

Fig.18

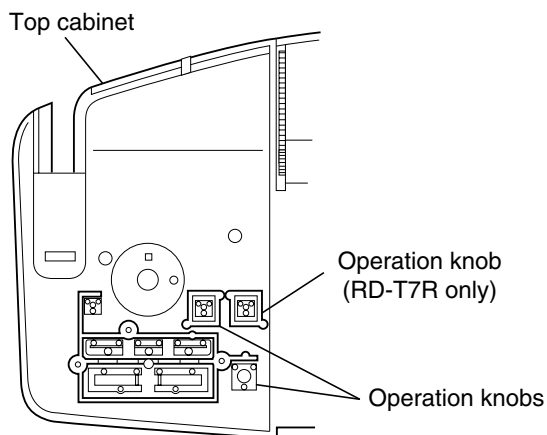

Fig.20

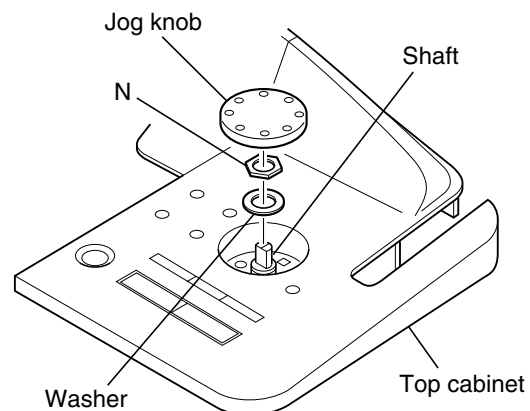

Fig.19

■ Removing the CD mechanism assembly (See Fig.21)

- Prior to performing the following procedures, remove the main board assembly.

1. Remove the four screws "P" retaining the CD mechanism assembly.

[Caution] When replacing the CD mechanism assembly, be sure not to mistake the positions of the red and green dampers.
(See Fig.22)

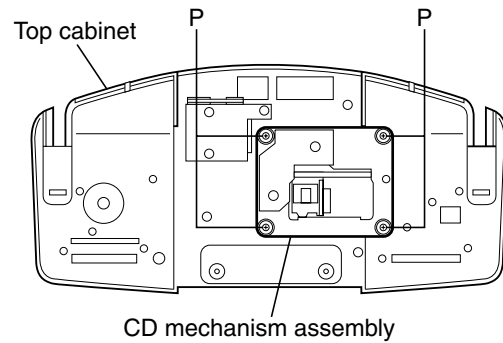

Fig.21

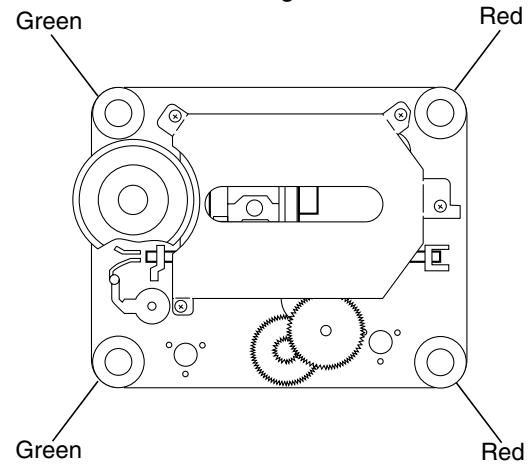

Fig.22

■ Replacing the loading belt and CD door motor (See Fig.23 and 24)

- Prior to performing the following procedures, remove the main board assembly.

1. Remove the loading belt from the pulley of the CD door motor.
2. Remove the wire from the CD door motor by accessing it through notch "i" on the CD door motor holder.
3. Remove the three screws "Q" retaining the CD door motor holder.
4. Remove the CD door motor.

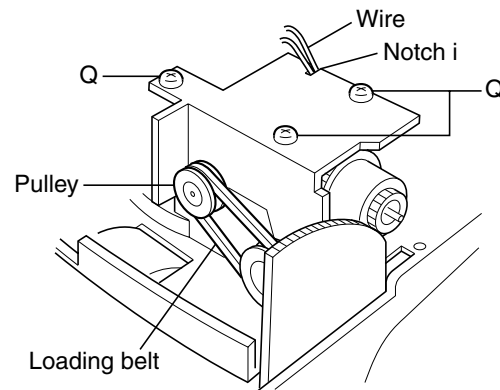

Fig.23

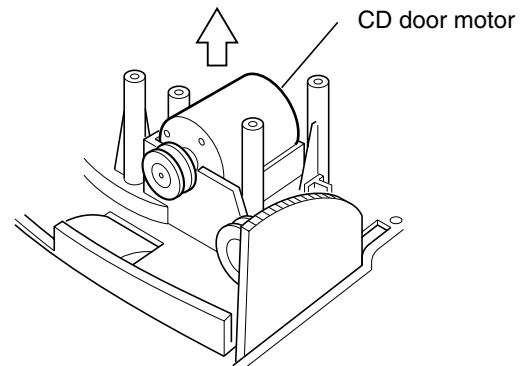

Fig.24

■ Removing the display board assembly (See Fig.25 to 27)

- Prior to performing the following procedures, remove the main board assembly.
 - Prior to performing the following procedures, remove the loading belt and CD door motor.
1. While keeping the sections "j" and "j" on the left and right sides of the top cabinet assembly in the direction of the arrow, remove the CD door from the top cabinet.
 2. Remove the two screws "R" retaining the CD door cover.
 3. Remove the two screws "S" and screw "T" retaining the display board assembly.

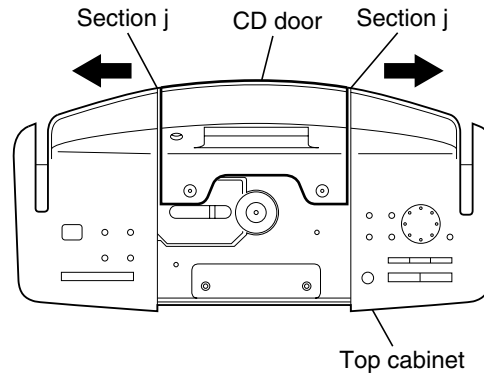

Fig.25

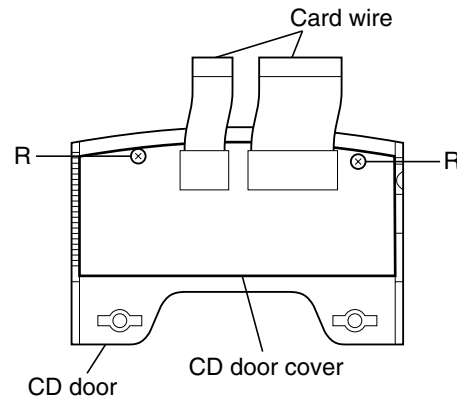

Fig.26

<CD mechanism section>

■ Removing the CD pickup unit (See Fig.28 and 29)

- Prior to performing the following procedures, remove the CD mechanism assembly.
1. Remove the four screws "U" retaining the CD cover plate.
 2. Widen the section "k".
 3. While keeping the section "k" wide open, push the section "l" in the direction of the arrow to remove the shaft, and then remove the CD pickup.

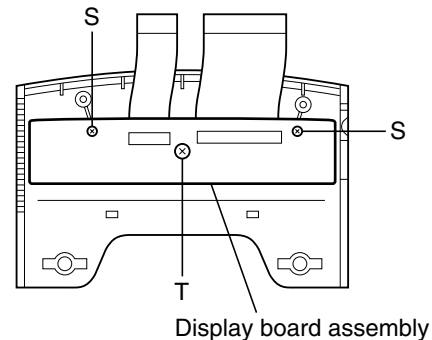

Fig.27

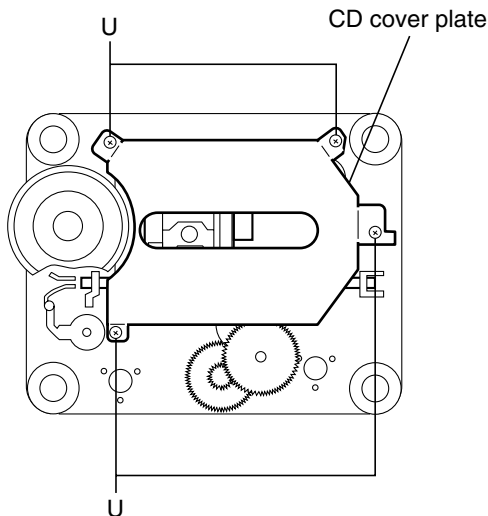

Fig.28

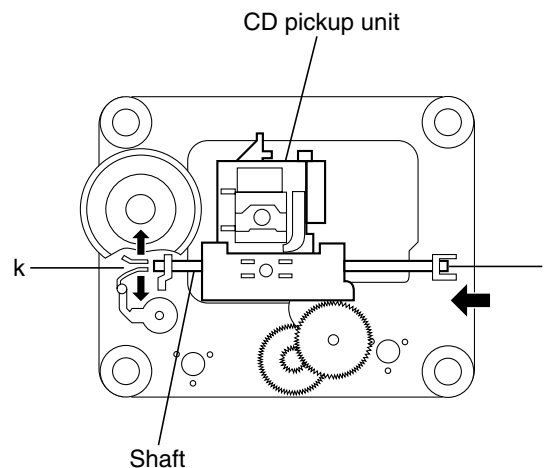

Fig.29

Adjustment method

Measurement instruments required for adjustment

1. Low frequency oscillator,
This oscillator should have a capacity to output 0dB to 600ohm at an oscillation frequency of 50Hz-20kHz.
2. Signal generator
3. Electronic voltmeter
4. Test disc
: CTS-1000(12cm),GRG-1211(8cm)

Measurement conditions

Power supply voltage
AC120V (60Hz)

Radio input signal

AM modulation frequency : 400Hz
Modulation factor : 30%
FM modulation frequency : 400Hz
Frequency displacement : 22.5kHz

Frequency Range

FM 87.5MHz~108MHz
MW 530kHz~1710kHz

Standard measurement positions of volume and switch

Power : Standby (Light STANDBY Indicator)
AHB (Active Hyper Bass) : OFF
Main VOL. : 0 Minimum

Precautions for measurement

1. Apply 30pF and 33kohm to the IF sweeper output side and 0.082 μ F and 100kohm in series to the sweeper input side.
2. The IF sweeper output level should be made as low as possible within the adjustable range.
3. Since the IF sweeper is a fixed device, there is no need to adjust this sweeper.
4. Since a ceramic oscillator is used, there is no need to perform any MPX adjustment.
5. Since a fixed coil is used, there is no need to adjust the FM tracking.
6. The input and output earth systems are separated. In case of simultaneously measuring the voltage in both of the input and output systems with an electronic voltmeter for two channels, therefore, the earth should be connected particularly.
7. In the case of BTL connection amplifier, the minus terminal of speaker is not for earthing. Therefore, be sure not to connect any other earth terminal to this terminal. This system is of an OTL system.

■ Arrangement of adjusting positions

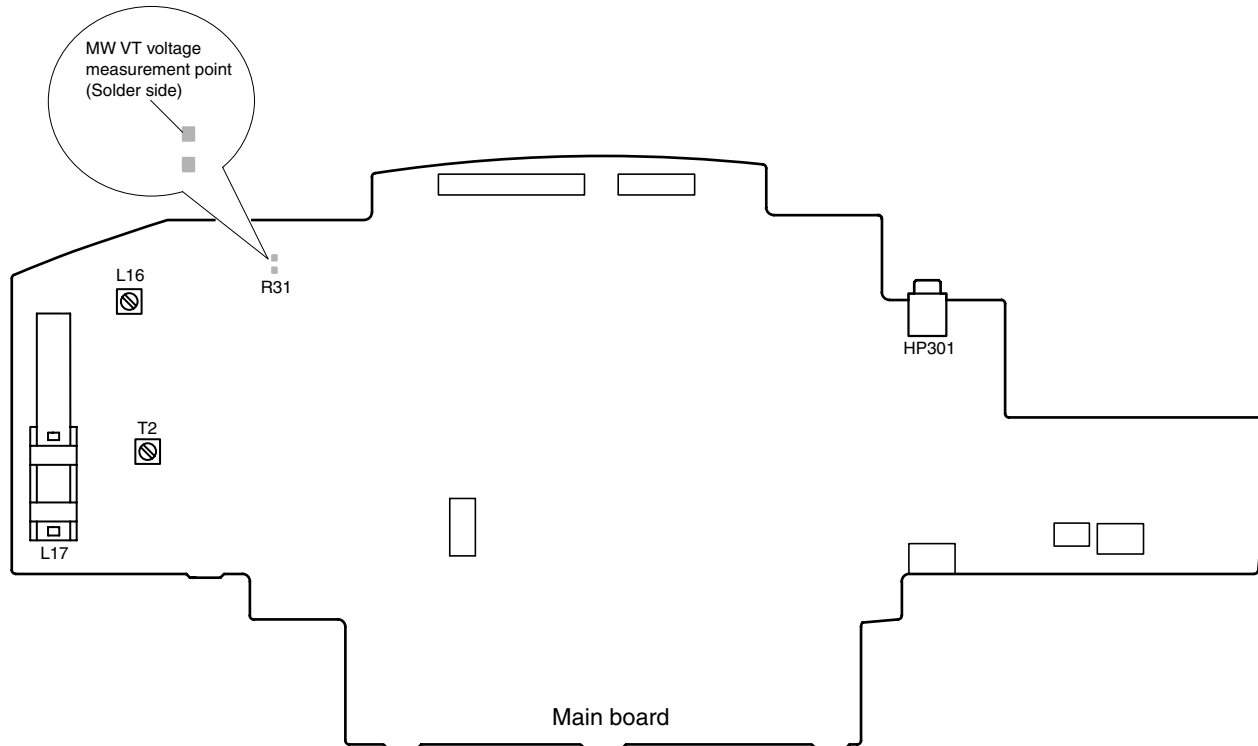

■ Tuner section

Items	Measurement conditions	Measurement method	Standard values	Adjusting positions
AM Tracking Alignments	Input signal MW:530kHz Measurement point : Resistor (R31) terminal	OSC coil adjustment 1. Set the Signal Generator signal to 530kHz and feed it to Loop Antenna. 2. Receiving the signal and adjust the OSC coil L16 obtain the V.T is 1.40V +/- 0.05V. 3. After adjustment, confirm that the AM tuner is receivable normally on 1710kHz frequency.	V.T MW: 1.40V +/- 0.05V	OSC coil: L16 Adjust the OSC coil only when the AM coil block has been changed.
	Input signal : 600kHz	Antenna coil check or adjustment 1. Change the receiving frequency to 600kHz. 2. Check the Antenna coil L17 obtain maximum sensitivity. Perform this adjustment when required. (Adjust the SSG output to out of AGC range.)	Maximum sensitivity	Antenna coil : L17
AM IFT Alignments	Input signal : 530kHz	1. Set the receiving frequency to 530kHz. 2. Feed the 450kHz signal to AM IF input. 3. Adjust the IFT Block T2 obtain to maximum output. (Adjust the SSG output to out of AGC range.)	Maximum output	IFT(T2) Adjust the IFT only when the IFT block has been changed.

Note: The adjustment of CD section is not required.

Flow of functional operation until TOC read

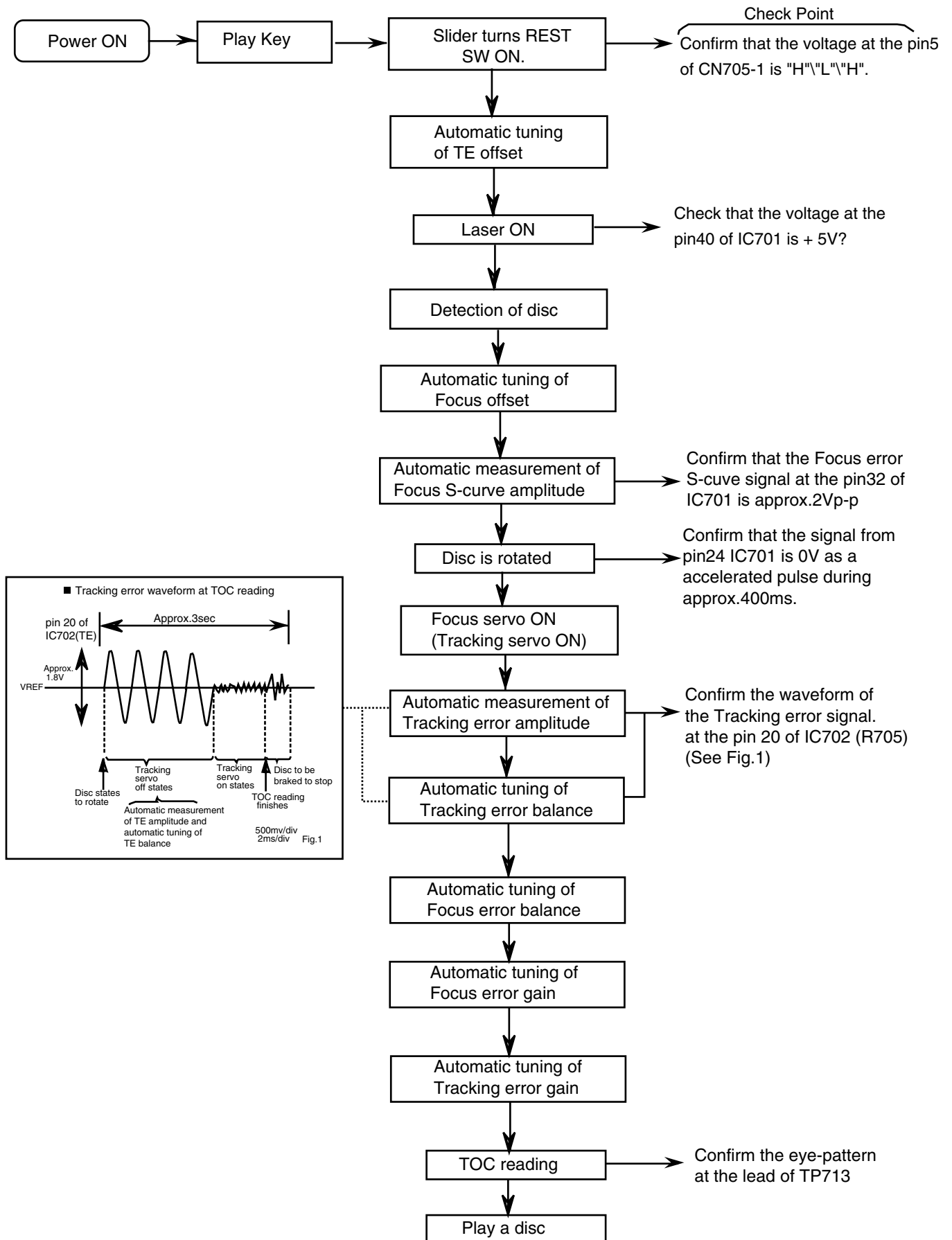

Maintenance of laser pickup

(1) Cleaning the pick up lens

Before you replace the pick up, please try to clean the lens with a alcohol soaked cotton swab.

(2) Life of the laser diode

When the life of the laser diode has expired, the following symptoms will appear.

1. The level of RF output (EFM output:amplitude of eye pattern) will below.

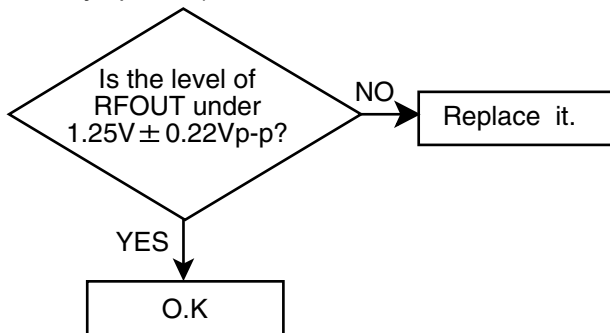

Replacement of laser pickup

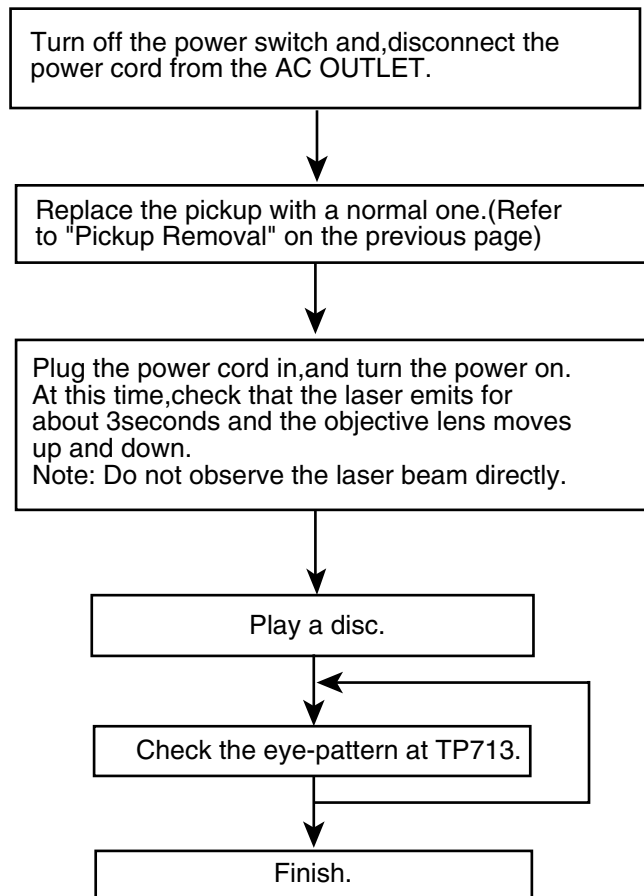

(3) Semi-fixed resistor on the APC PC board

The semi-fixed resistor on the APC printed circuit board which is attached to the pickup is used to adjust the laser power.Since this adjustment should be performed to match the characteristics of the whole optical block, do not touch the semi-fixed resistor.

If the laser power is lower than the specified value,the laser diode is almost worn out, and the laser pickup should be replaced.

If the semi-fixed resistor would be adjusted when the pickup operates normally,the laser pickup may be damaged due to excessive current.

Description of major ICs

■ AN22000A (IC702) : CD-DA head amplifier

1. Terminal layout

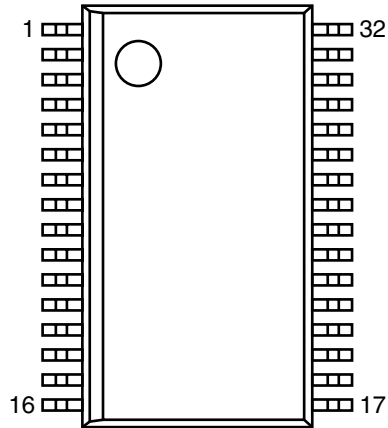

2. Pin function

Pin No.	Symbol	I/O	Function	Pin No.	Symbol	I/O	Function
1	PD	I	APC Amp. input terminal	15	NRFDET	O	NRFDET output terminal
2	LD	O	APC Amp. output terminal	16	GND	-	Ground
3	VCC	-	Power supply terminal	17	VREF	O	VREF output terminal
4	RFN	I	RF adder Amp. inverting input terminal	18	VDET	O	VDET output terminal
5	RFOUT	O	RF adder Amp. output terminal	19	TEBPF	I	VDET output terminal
6	RFIN	I	AGC input terminal	20	TEOUT	O	TE Amp. output terminal
7	CAGC	I	Input terminal for AGC loop filter capacitor	21	TEN	I	TE Amp. inverting input terminal
8	ARF	O	AGC output terminal	22	FEN	I	FE Amp. inverting input terminal
9	CBA	I	Capacitor connecting terminal for HPF-Amp.	23	FEOUT	O	FE Amp. output terminal
10	3TOUT	O	3 TENV output terminal	24	GCTL	O	GCTL & APC terminal
11	CBOO	I	Capacitor connecting terminal for envelope detection on the darkness side	25	FBAL	O	FBAL control terminal
12	BDO	O	BDO output terminal	26	TBAL	O	TBAL control terminal
13	COFTR	I	Capacitor connecting terminal for envelope detection on the light side	27	E	I	Tracking signal input terminal 1
14	OFTR	O	OFTR output terminal	28	F	I	Tracking signal input terminal 2
				29	D	I	Focus signal input terminal 4
				30	B	I	Focus signal input terminal 3
				31	C	I	Focus signal input terminal 2
				32	A	I	Focus signal input terminal 1

3. Block diagram

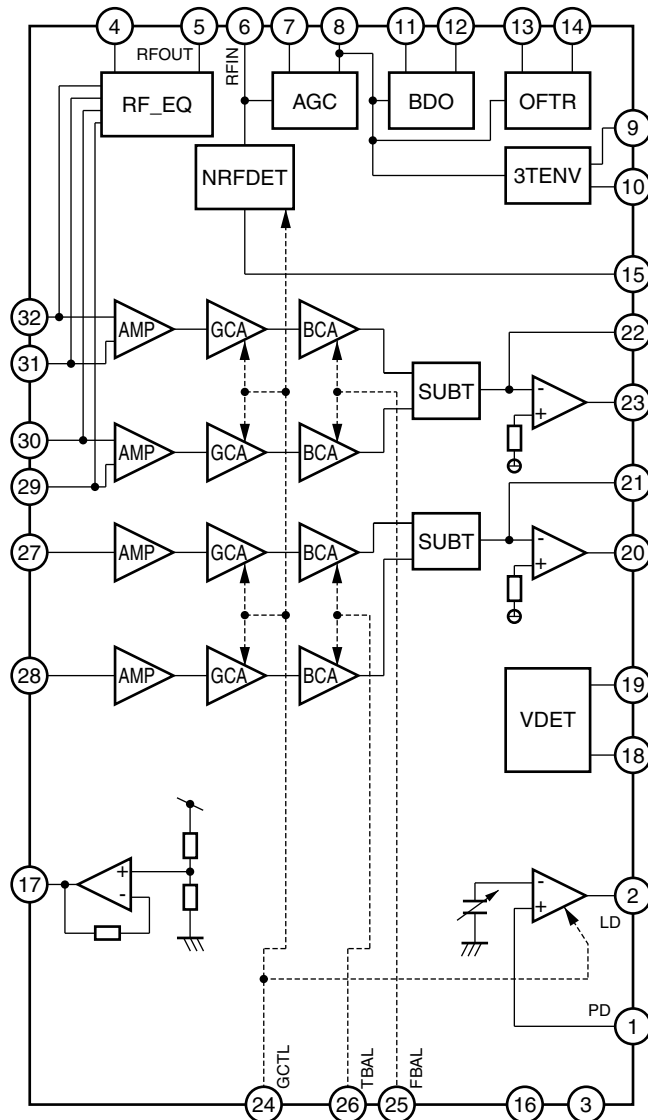

■ **BA15218 (IC401) : Dual low noise operational amplifier**

1. Terminal layout

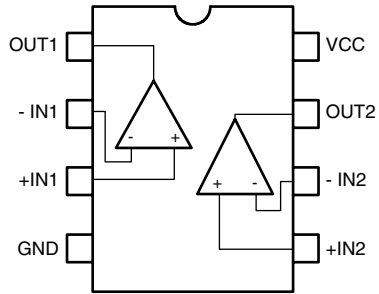

■ **BA6897FP (IC703) : 4channel driver**

1. Terminal layout & Block diagram

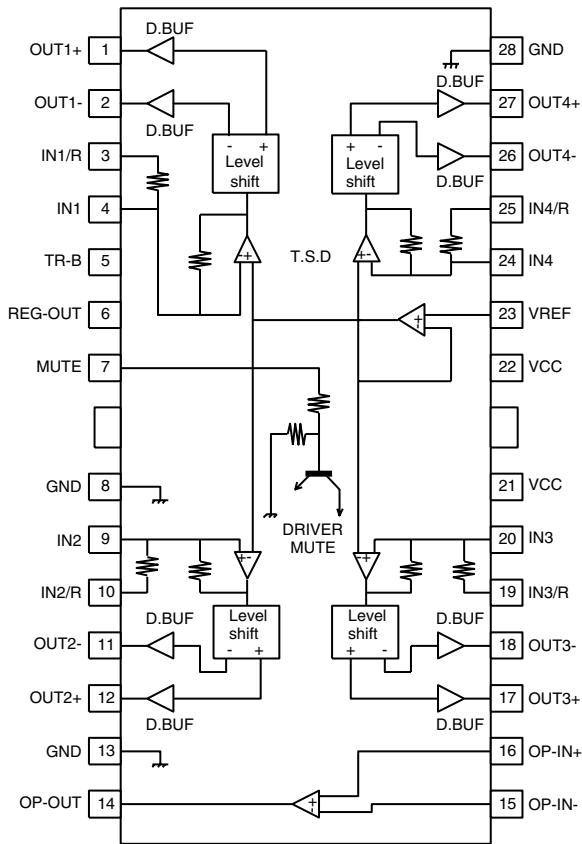

■ LA1823 (IC5) : 1chip AM/FM, MPX tuner system

1. Block diagram

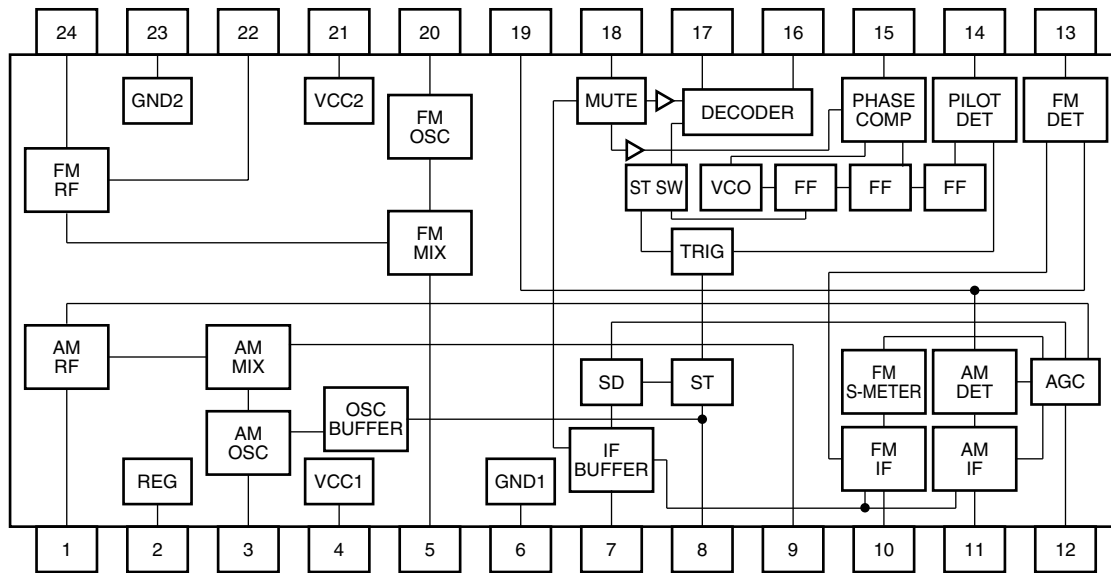

2. Pin function

Pin No.	Symbol	I/O	Function	Pin No.	Symbol	I/O	Function
1	AM_RFIN	I	AMRF signal input	13	FM_DET	O	FM detection signal output
2	REG.	I	AMRF signal input	14	ST/MON_SW	I	Stereo/Monaural switching signal input
3	AM_OSC	-	AM local oscillation circuit	15	AM/FM_SW	I	AM/FM switching signal input
4	VCC_1	-	Power supply terminal	16	L_OUT	O	Output L-channel
5	FM_MIXOUT	O	Output terminal for FM mixer	17	R_OUT	O	Output R-channel
6	GND_1	-	Ground	18	MPX_IN	I	Multiplex signal input
7	IF_BUFFER	O	IF buffer output	19	DET_OUT	O	AM/FM detection output
8	ST_IND	O	Stereo indicator output	20	FM_OSC	-	FM local oscillation circuit
9	AM_MIXOUT	O	Output terminal for AM mixer	21	VCC_2	-	Power supply terminal
10	FM_IF IN	I	Input of FMIF signal	22	FM_RFOUT	O	Output of FMRF signal
11	AM_IF IN	I	Input of AMIF signal	23	GND_2	-	Ground
12	AGC	I	AGC voltage input terminal	24	FM_RFIN	I	Input of FMRF signal

■ LC72136 (IC4) : PLL frequency synthesizer

1. Terminal layout

XTI	1	22	XT
FM	2	21	GND
CE	3	20	LPFI
DI	4	19	LPFO
CLOCK	5	18	PD
DO	6	17	VCC
VCOSTOP	7	16	FMIN
AM/FM	8	15	AMIN
LW	9	14	NC
MW	10	13	IFCNT
SDIN	11	12	IFIN

2. Block diagram

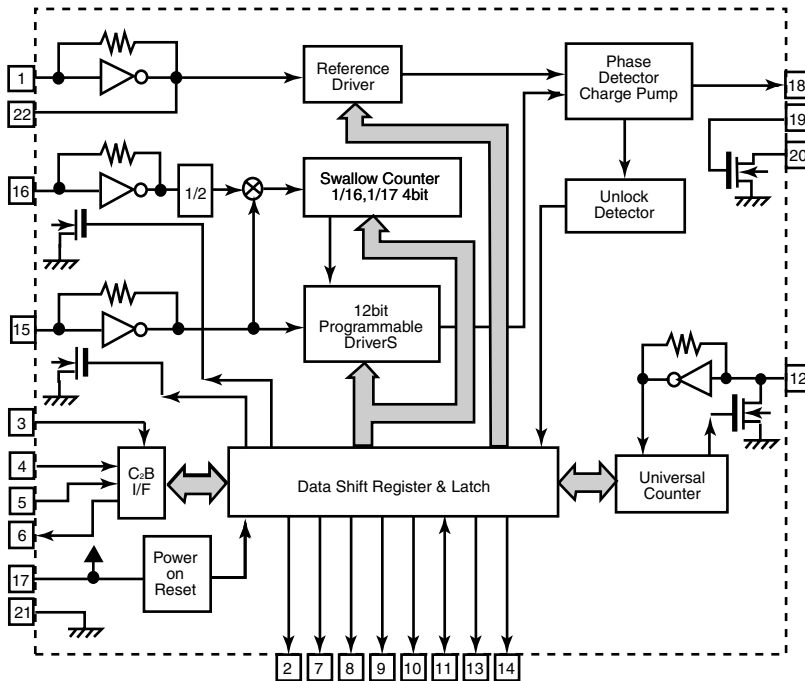

3. Pin function

Pin No.	Symbol	I/O	Function	Pin No.	Symbol	I/O	Function
1	XTI	I	X'tal oscillator connect (75KHz)	12	IFIN	I	IF counter signal input
2	FM	O	LOW:FM mode	13	IFCNT	O	IF signal output
3	CE	I	When data output/input for 4pin(input) and 6pin(output): H	14	NC	-	Not use
4	DI	I	Input for receive the serial data from controller	15	AMIN	I	AM Local OSC signal output
5	CLOCK	I	Sync signal input use	16	FMIN	I	FM Local OSC signal input
6	DO	O	Data output for Controller Output port	17	VCC	-	Power supply(VDD=4.5~ 5.5V) When power ON:Reset circuit move
7	VCOSTOP	O	"Low": MW mode	18	PD	O	PLL charge pump output(H: Local OSC frequency Height than Reference frequency. L: Low Agreement: Height impedance)
8	AM/FM	O	Open state after the power on reset	19	LPFO	O	Output for active lowpassfilter of PLL
9	LW	-	Not use	20	LPFI	I	Input for active lowpassfilter of PLL
10	MW	I	AM MW signal input	21	GND	-	Connected to GND
11	SDIN	I/O	Data input/output	22	XT	I	X'tal oscillator(75KHz)

■ LC75342 (IC301) : E. volume

1. Terminal layout

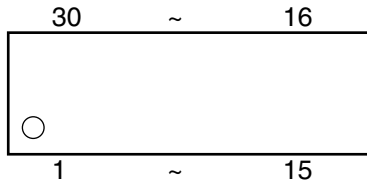

2. Block diagram

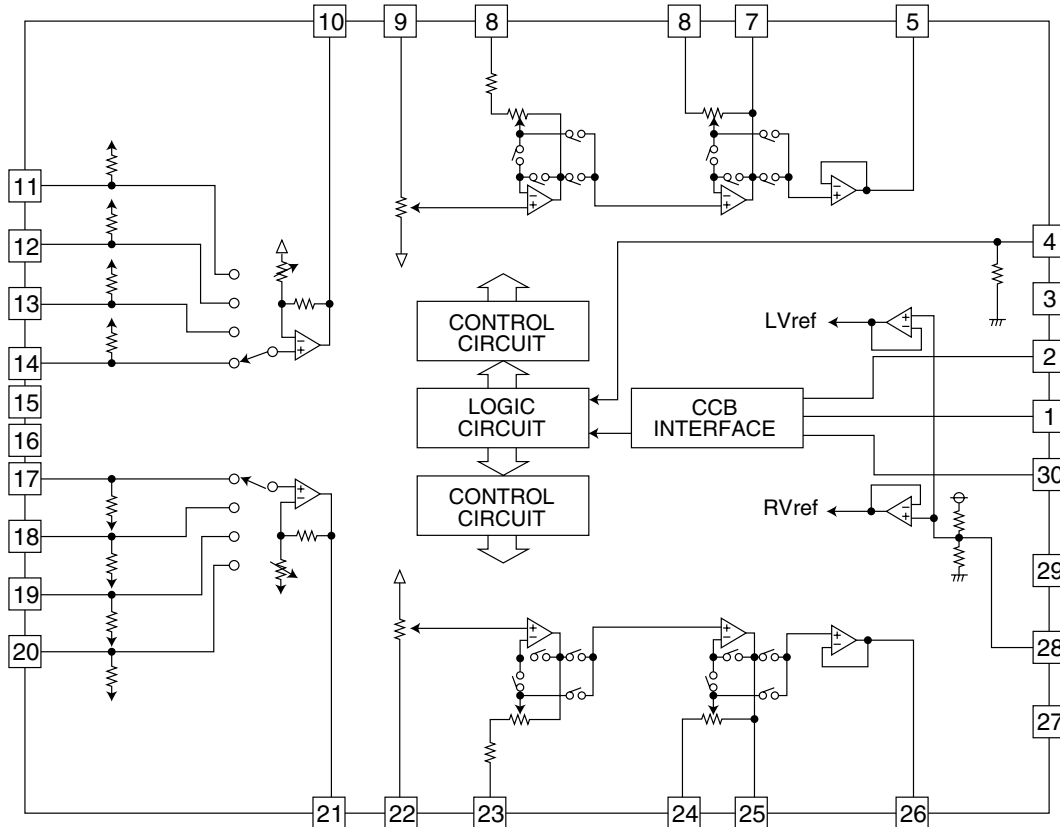

3. Pin function

Pin No.	Symbol	Function	Pin No.	Symbol	Function
1	DI	Serial data and clock input for IC control	17	R1	Input signal connections
2	CE	Chip enable	18	R2	Input signal connections
3	VSS	GND	19	R3	Input signal connections, not used
4	TEST	Electric volume connection for test	20	R4	Not used
5	LOUT	Volume control and equalizer input	21	RSELO	Input selector output
6	LBASS2	Connection for resistor and capacitor that from the bass band filter	22	RIN	Volume control and equalizer input
7	LBASS1	Connection for resistor and capacitor that from the bass band filter	23	RTRE	Connection for capacitor that from the treble band filter
8	LTRE	Connection for capacitor that from the treble band filter	24	RBASS1	Connection for resistor and capacitor that from the bass band filter
9	LIN	Volume control and equalizer input	25	RBASS2	Connection for resistor and capacitor that from the bass band filter
10	LSELO	Input selector output	26	ROUT	Volume control and equalizer input
11	L4	Not used	27	NC	Not used
12	L3	Input signal connections, not used	28	VREF	Connection to the 0.5X VDD voltage generator circuit used as the analog signal ground
13	L2	Input signal connections	29	VDD	Power supply
14	L1	Input signal connections	30	CL	Serial data and clock input for IC control
15	NC	GND			
16	NC	GND			

■ MN662748RPMFA (IC701) : Digital servo & Digital signal processor

1. Terminal layout

● 80~61	
1	60
2	59
20	41
21~40	

2. Pin function

Pin No	Symbol	I/O	Function	Pin No	Symbol	I/O	Function
1	BCLK	-	Not use	41	PLL2	-	Not use
2	LRCK	-	Not use	42	TOFS	-	Not use
3	SRDATA	-	Not use	43	WVEL	-	Not use
4	DVDDI	-	Power supply for digital circuit	44	ARF	I	RF signal input
5	DVSSI	-	GND for digital circuit	45	IREF	I	Reference current input
6	TX	-	Not use	46	DRF	I	Bias pin for DSL
7	MCLK	I	Micro computer command clock signal input	47	DSL	I/O	Loop filter pin for DSL
8	MDATA	I	Micro computer command data input	48	PLLF	I/O	Loop filter pin for PLL
9	MLD	I	Micro computer command load signal input (L: Load)	49	VCOF	I/O	Loop filter pin for VCO
10	SENSE	-	Not use, connect to TP716	50	AVDD2	-	Power supply for analog circuit
11	FLOCK	-	Not use, connect to TP717	51	AVSS2	-	GND for analog circuit
12	TLOCK	-	Not use, connect to TP718	52	EFM	-	Not use, connect to TP724
13	BLKCK	O	Sub code block clock signal output	53	PCK	O	Clock output for PLL
14	SQCK	I	External clock input for sub code Q register input	54	VCOF2	I/O	Loop filter pin for Digital servo VCO
15	SUBQ	O	Sub code Q data output	55	SUBC	-	Not use
16	DMUTE	-	Not use, connect to TP719	56	SBCK	-	Not use
17	STAT	O	Status signal input	57	VSS	-	GND for crystal oscillation circuit
18	RST	I	Reset signal input (L: Reset)	58	X1	I	Input for crystal oscillation circuit (f=16.9344MHz)
19	SMCK	-	Not use	59	X2	O	Output for crystal oscillation circuit (f=16.9344MHz)
20	PMCK	-	Not use, connect to TP720	60	VDD	-	Power supply for crystal oscillation circuit
21	TRV	O	Traverse enforced output	61	BYTCK/TRVSTP	-	Not use
22	TVD	O	Traverse drive output	62	CLDCK	O	Sub code frame clock signal output
23	PC	-	Not used	63	FCLK	-	Not used
24	ECM	O	Spindle motor drive signal (Enforced mode output)	64	IPFLAG	O	Interpolation flag signal output, Connect to TP721
25	ECS	O	Spindle motor drive signal (Servo error signal output)	65	FLAG	O	Flag signal output, Connect to TP722
26	KICK	O	Kick pulse output	66	CLVS	-	Not use
27	TRD	O	Tracking drive output	67	CRC	-	Not use
28	FOD	O	Focus drive output	68	DEMPH	O	De-emphasis detect signal output, Connect to TP723
29	VREF	I	Reference voltage for D/A output block	69	RESY	-	Not use
30	FBAL	O	Focus balance adjust signal output	70	IOSEL	I	Mode select pin, Connect to DVDD1 (H fix)
31	TBAL	O	Tracking balance adjust signal output	71	/TEST	I	Test pin, Connect to DVDD1 (H fix)
32	FE	I	Focus error signal input (Analog input)	72	AVDD1	-	Power supply for analog circuit
33	TE	I	Tracking error signal input (Analog input)	73	OUTL	O	L-channel audio output
34	RFENV	I	RF envelope signal input (Analog input)	74	AVSS1	-	GND for analog circuit
35	VDET	I	Vibration detect signal input (H:Detect)	75	OUTR	O	R-channel audio output
36	OFT	I	Off track signal input (H:Off track)	76	RSEL	I	RF signal polarity setting pin, Connect to DVDD1 (H fix)
37	TRCRS	I	Track cross signal input	77	CSEL	I	Oscillation frequency setting pin, Connect to GND (L fix)
38	/RFDET	I	RF detect signal input (L:Detect)	78	PSEL	I	IOSEL=H, Test pin, Connect to GND (L fix)
39	BDO	I	Drop out signal input (H:Drop out)	79	MSEL	I	IOSEL=H, SMCK output, Frequency select pin
40	LDON	O	Laser on signal output (H:ON)	80	SSEL	I	IOSEL=H, SMCK output, SUBQ output mode select pin

■ MN101C38CYD (IC801) : System controller

1. Terminal layout

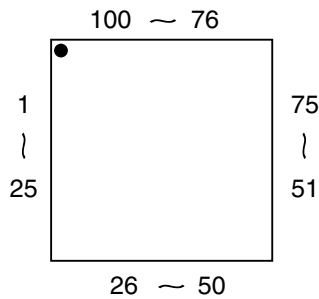

2. Pin function

Pin No.	Symbol	I/O	Function
1~4	COM 4~1	O	LCD common outputs
5~7	VLC 3~1	-	LCD power supply
8	VDD	-	Power supply
9	OSC2	O	Clock output (8MHz)
10	OSC1	I	Clock input (8MHz)
11	VSS	-	Ground
12	XI	I	Sub clock input (32.768kHz)
13	XO	O	Sub clock output (32.768kHz)
14	MMOD	I	Memory mode switch input
15	VREF-	-	-Power supply for A/D converter
16~18	KEY1~3	I	Control key signal input
19	SFTY	I	Safety check for power off
20, 21	VOL1, 2	I	Rotary digital encoder input
22	ACCHK	I	AC operate
23	PCHK	I	Power supply check
24	VREF+	I	+Power supply for A/D converter
25	VDAT	O	Common data, PLL & volume
26	SDI	I	PLL data input
27	VCK	O	Common CLK, PLL & volume
28	VCE	O	Common CE, PLL & volume
29	SUBQ	I	CD subcode data input
30	SQCK	O	CD subcode clock output
31	SHIFT	O	8MHz clock shift for FM receiving
32	MRST	I	Reset input
33	PCNT	O	Power ON/OFF control
34	FTU	O	Radio VDD switching control
35	FCD	O	CD 5V control
36	AHB	O	Active bass
37	SMUTE	O	Signal muting by muting circuit
38	REM	I	Remote control signal input
39	BLKCK	I	CD subcode block clock 75Hz input
40	RDDI	I	RDS data from decoder IC
41	INH	I	Inhibit input
42	RDCK	I	RDS clock from decoder IC
43	AL2	O	Alarm 2 output
44~46	BUZ1~3	O	Buzzer signal
47	POWER	I	Power key input
48	RESERVE2	-	Not use
49	REST	I	Pickup rest position input
50	MDAT	O	CD common data output
51	MLD	O	CD data latch output
52	MCLK	O	CD common clock output
53	RESERVE3	O	Not use
54	GVP	O	Not use
55	MOMU	O	Motor driver mute control
56	XRST	O	CD reset output
57	STAT	I	Status signal input
58	LED1	O	Power/standby LED
59	MPX	I	Stereo indicator I/P
60	OSW	I	Door open contact switch
61	CSW	I	Door close contact switch
62	LOAD	I	Door is locked signal
63	OCTL	O	Door open control
64	CCTL	O	Door close control
65	SCTL	O	Door speed down
66	BLIGHT	O	Backlight LED
67~100	SEG34~1	O	LCD segment output

■ **TA8227 (IC302) : Power amplifier**

1. Terminal layout

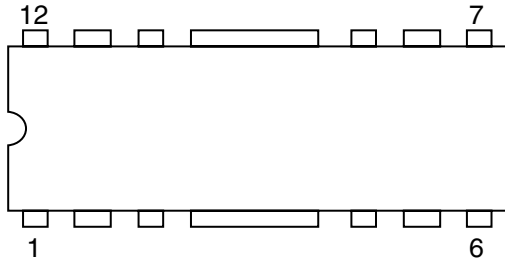

2. Block diagram

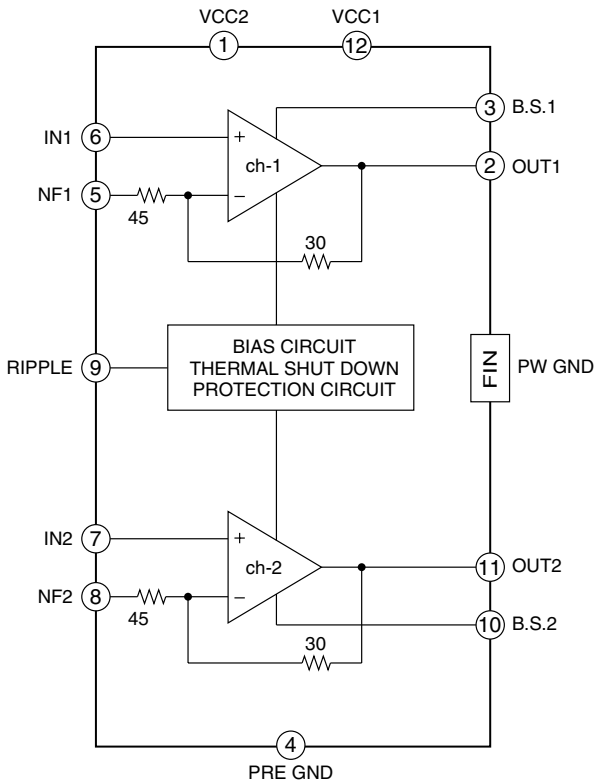

■ **TA8409S (IC704) : Motor driver**

1. Terminal layout

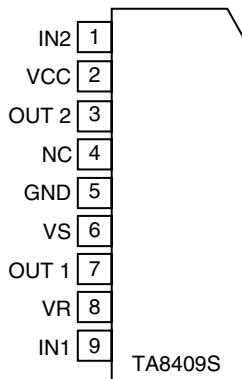

2. Pin function

INPUT		OUTPUT		MODE
IN1	IN2	OUT1	OUT2	MOTOR
0	0	∞	∞	STOP
1	0	H	L	CW/CCW
0	1	L	H	CCW/CW
1	1	L	L	BRAKE

Wiring connection

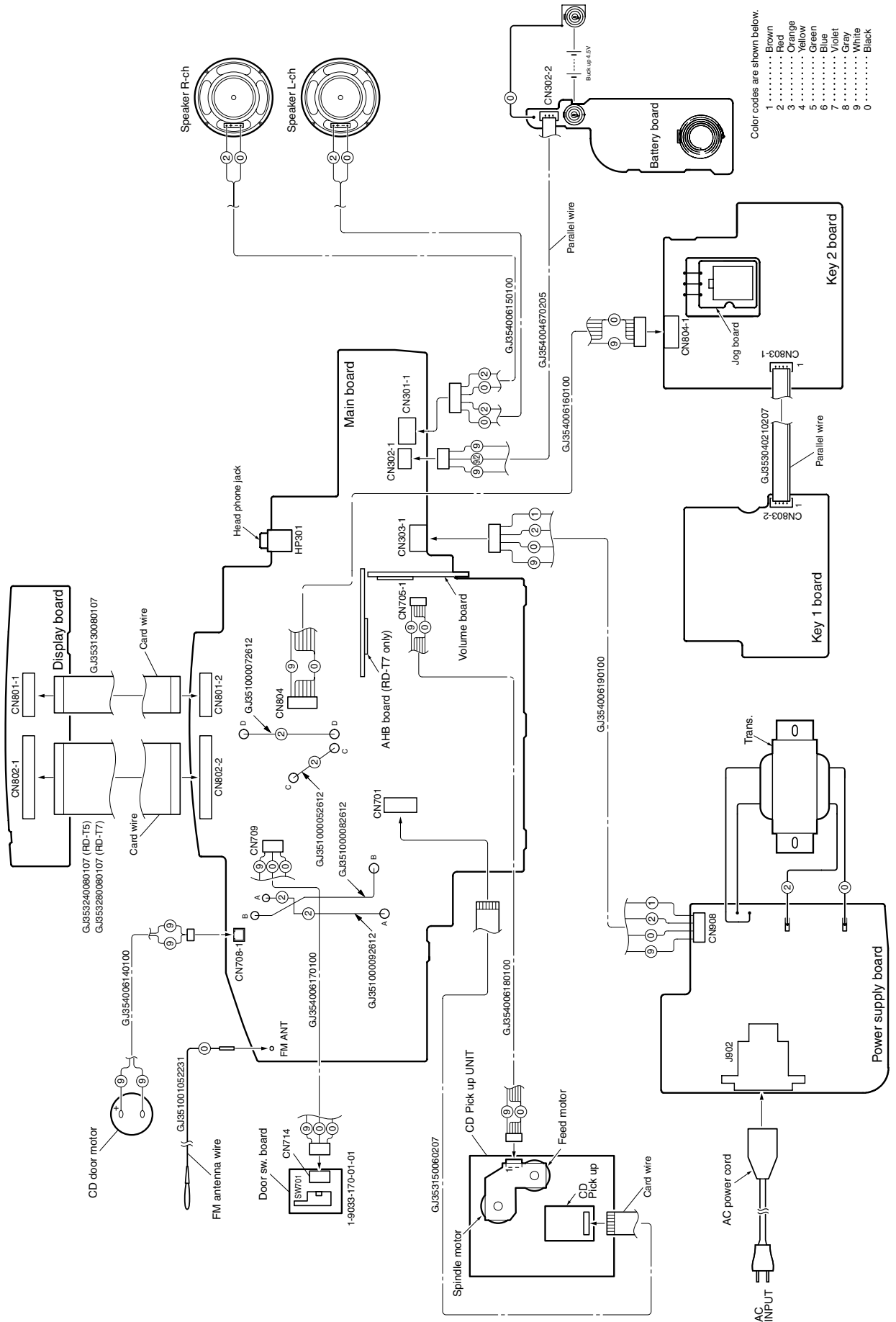



VICTOR COMPANY OF JAPAN, LIMITED

AUDIO & COMMUNICATION BUSINESS DIVISION

PERSONAL & MOBILE NETWORK B.U. 10-1, 1Chome, Ohwatari-machi, maebashi-city, 371-8543, Japan